

**ITEC<sup>®</sup>**  
**FRONTMATEC**  
 By Fortifi

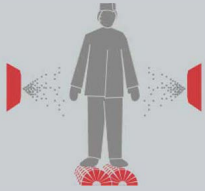

## Walk-through boot cleaning machine type 23835-1000



Photo 2: Brushes

**HYGIENE**

≡ Ergonomically shaped stainless steel housing and special brush arrangement for the comfortable walking through the machine.

≡ Antislip surfaces, step guides, rails, as well as the step treads, integrated into the housing, provide a secure standing.



## Quick and ergonomic cleaning and disinfection of sole and leg

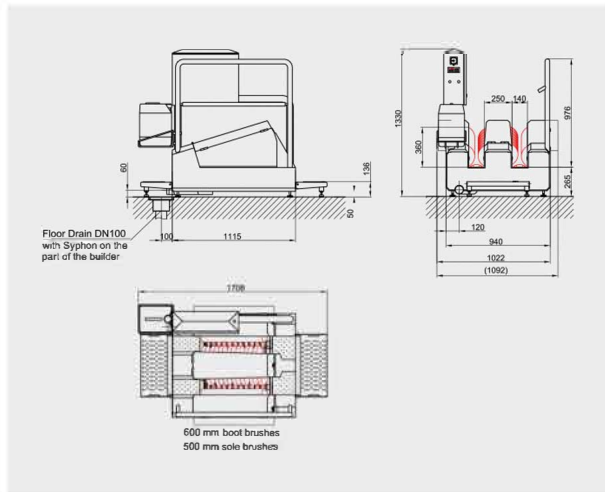

### Technical data: Type 23835

Power supply voltage:	400 V, 3 / N / PE
Nominal power:	1,5 kW
Power frequency:	50 - 60 Hz
Control voltage:	24 V DC
Protection class:	IP 65
Room temperature:	min. +4°C, max. +40°C
Water supply:	MW R 1/2" (T max = 43°)
Wastewater drain:	R 2 1/2"

≡ The cleaning appliance type corresponds to the strict EU and US hygiene prescriptions as well as to the valid regulations of the TÜV and the VDE-guidelines.

≡ The walk-through boot cleaning machine type 23835 is completely equipped with internal pipework and can directly be put into operation. Siphon, water intake, drain, sealing and small parts, however, do not belong to the delivery.

Technical changes subject to alterations.

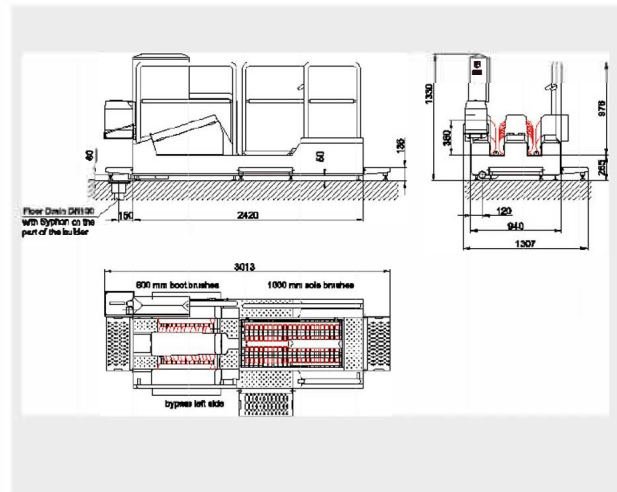

### Technical data: Type 23835-1000

Power supply voltage:	400 V, 3 / N / PE
Nominal power:	1,5 kW
Power frequency:	50 - 60 Hz
Control voltage:	24 V DC
Protection class:	IP 65
Room temperature:	min. +4°C, max. +40°C
Water supply:	MW R 1/2" (T max = 43°)
Wastewater drain:	R 2 1/2"

≡ The cleaning appliance type corresponds to the strict EU and US hygiene prescriptions as well as to the valid regulations of the TÜV and the VDE-guidelines.

≡ The walk-through boot cleaning machine type 23835-1000 is completely equipped with internal pipework and can directly be put into operation. Siphon, water intake, drain, sealing and small parts, however, do not belong to the delivery.

Technical changes subject to alterations.



more than **HYGIENE**

- ≡ Cutting
- ≡ Packing
- ≡ Separator
- ≡ Logistic
- ≡ Automatic
- ≡ Service
- ≡ Storage
- ≡ Ergonomic
- ≡ Engineering

### ITEC GmbH

Auf dem Tigge 60 b + c  
 D-59269 Beckum-Westfalen  
 Deutschland  
 Phone +49 25 21 - 85 07 0  
 Fax +49 25 21 - 85 07 90  
 www.itec.de • info@itec.de

36412 GB

