

**ITEC<sup>®</sup>**  
**FRONTMATEC**  
 By Fortifi

Boot cleaner type 23800

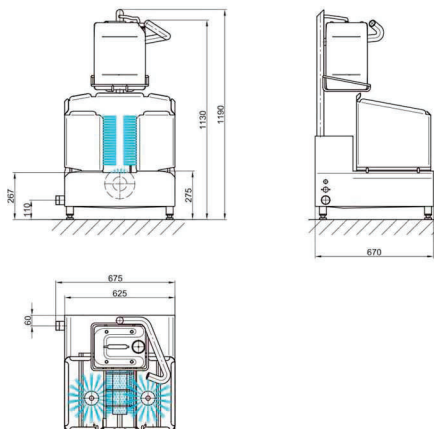

## Optimal cleaning and hygiene

- Cleaning of bootleg and sole by rotating brushes
- Touch sensor in the handle to start the cleaning process
- Cleaning in two phases:
  1. Cleaning detergent is supplied to each brush using separate spray-pipes and mixed with water
  2. Rinsing with water
- Short cleaning time at low operation cost
- Splash protection by special casing
- Brushes can be removed without tools
- Easy to clean
- Separation of pipes according to DVGW regulation
- Conform to EU and US hygiene regulations, the valid regulations of the TÜV as well as the VDE guidelines
- The device will be delivered with mains plug (Siphon, water connection, sewage drain, sealing and small parts are not included)

### Technical data

Type	Sole cleaner type 23800
Power supply	400V, 3/N/PE
Mains frequency	50-60 Hz
Power consumption	0.75 kW
Control voltage	24V DC
Protection class	IP65
Water supply	3/4" WW, max. 40°C
Drain	1 1/2"
Water consumption	2 l per cleaning process
Cleaning time	5-10 sec. per boot

Technical data may be subject to changes

